



An ISO 9001:2000 Certified Company

Autocar 4x2 DOT/EPA Terminal Tractor Standard Specifications

Engine and Equipment	Standard	Optional
Engine model	Cummins ISB diesel - 200 HP @ 2600 RPM 520 ft-lb torque @ 1600 RPM	
Exhaust	Horizontal DPF w/ vertical tailpipe	
Air cleaner	Donaldson 11 inch single stage	
Radiator	1050 sq in copper brass	
Fan & drive	Direct drive	<i>(optional 2-speed drive available)</i>
Coolant hoses/piping	Silicone hoses with steel tubing	
Coolant	Extended life coolant	

Transmission and Equipment

Transmission model	Allison 3000 RDS	<i>(optional Allison 3500 RDS available)</i>
Transmission gearing	4-speed	<i>(optional 3-speed or 5-speed available)</i>
Transmission controls	Allison push button	<i>(optional Allison t-handle available)</i>
Transmission cooler	Oil to water type	
Transmission lubricant	TranSynd™ synthetic	
Driveshaft	Dana Spicer® 1710 half-round	

Front Axle and Equipment

Axle model	Dana Spicer® E-1322-W (13,200 lb rated)	
Front suspension	Flat leaf (14,500 lb rated)	
Shock absorbers	Double acting - heavy duty	
Power steering	Gearbox, integral steering w/ mechanical backup	
Power steering reservoir	Integral w/ hydraulic tank	
ABS	Bendix 4S4M w/o traction control	<i>(required for vehicle speeds over 33 MPH)</i>
Brakes	16.5 x 5 s-cam	
Brake drums	Cast iron	
Slack adjusters	Automatic	
Front hubs	Iron hub piloted	

Rear Axle and Equipment

Axle model	Dana Spicer® S23-170 (single reduction)	<i>(optional Dana Spicer® axles available)</i>
Rear axle ratio	7.17:1	<i>(optional ratios available)</i>
Rear suspension	Solid	
ABS	Bendix 4S4M w/o traction control	<i>(required for vehicle speeds over 33 MPH)</i>
Brakes	16.5 x 7 s-cam	
Brake drums	Cast iron	
Slack adjusters	Automatic	
Rear hubs	Iron hub piloted	
Gear lubricant	Synthetic	

Chassis and Equipment

Wheelbase	116 inch	
Frame	2.0 million RBM, 50,000 KSI steel, 'C'-reinforced	
Frame fasteners	Huck bolts where possible	
Bumper	Steel	
Tow device(s)	Front & rear tow eyes	
Mud flaps	Rear of drive tires	<i>(optional mud flap configurations available)</i>

Pneumatic System (Rapid Fill)

Air compressor	Wabco 18.7 CFM	
Air system drain valve	Manual petcocks all tanks	
Air lines	Nylon, color coded	

Fuel System

Fuel tank	50 gallon steel rectangular w/ steps, left side mounted	
Fuel filter	Cummins	
Fuel lines	SAE J844 nylon	

5th Wheel and Hydraulic System

5th wheel	SAF/Holland 70,000 lb semi-oscillating 16 inch lift <i>(optional SAF/Holland 100,000 lb available)</i>
Hydraulic lift cylinders	(2) 5 inch 50,000 lb capacity
Hydraulic tank	15 gallon steel tank w/ sight glass
Pump	Engine mounted

Trailer Equipment

Air connections	12 ft color coded coiled w/ glad-hands	<i>(optional break-away glad-hands available)</i>
7-way electric cable receptacle		
7-way electric cable	12 ft coiled detachable	

Tires and Wheels

Front tires	11R22.5 LRG
Front wheels	Steel 22.5 x 8.25 hub piloted, 285mm BC
Rear tires	11R22.5 LRG
Rear wheels	Steel 22.5 x 8.25 hub piloted, 285mm BC

Electrical System

Electrical System	12V, negative ground	
Alternator	Delco Remy 22SI 130AMP	
Starter	Denso 12V	
Batteries	2 group 31 1900 CCA (min)	
Circuit protection	Automatic circuit breakers	
Windshield wipers	Single electric (pantograph) overhead	
Backup alarm	Non-motion detecting	<i>(optional motion detecting available)</i>
Horn	Single	

Lighting

Headlamps	Low/high sealed beam
Backup light, stop and turn signals	Shock resistant mounting
BOC 5th wheel light	Shock resistant mounting

Cab and Equipment

Cab construction	• Electrocoated (e-coated) steel, full cab immersion •	
Cab dimensions (outside)	Raised roof, 52" wide x 71" deep (w/o rear door) x 78" high (deck to roof)	
Cab doors	Left side hinged door w/ manual crank window, sliding rear door	
Rear door opening (useable)	24" wide x 72" high	
Cab floor	Sweep out floor w/ durable mat	
Cab dash	Steel wrap around	
Overhead console		
Cab mounting	4 point, rear air	
Cab tilt	Electric over hydraulic	
Glass	Tinted	
Mirrors	Dual SST west coast mirrors	<i>(optional convex, heated available)</i>
Cab climate control system	44,000 BTU fresh air heater	<i>(optional A/C available)</i>
Steering column	Fixed	
Steering wheel	16 inch 3-spoke	
Seat	Bostrom Baja mid-back air suspension	<i>(optional Bostrom T915 mid-back available)</i>
Seat covering	Black Cordura Plus® cloth fabric	
Seat belt	3-point black	<i>(optional 3-point orange available)</i>
Dome light		
Power ports	(2) 12V	<i>(optional (1) cigar lighter/(1) 12V available)</i>
Air horns	Mounted under cab	
Translucent sun visor(s)	Dual	
Conspicuity tape		

Operators Controls

Park brake - push/pull
Headlamps
Turn signal - column mounted
Brake pedal
Accelerator pedal
5th wheel height control
5th wheel lock
Transmission gear selector - T handle

Cab Instrumentation

Speedometer
Tachometer
Engine oil pressure
Coolant temperature
Transmission oil temperature
Voltmeter
Fuel level
Primary (A) air pressure
Secondary (B) air pressure
Hour meter (included in tachometer)

Cab Warning Devices

Park brake
High beam
Turn signal
Low fuel
Low air
Seat belt
DPF
HEST

Paint

Cab	White	(optional customer specific colors available)
Chassis	Black	(optional customer specific colors available)
Bumper	Black	(optional customer specific colors available)
Wheels	White powder coat	(optional customer specific colors available)

Optional Equipment

Air Dryer	Glad-hand and 7-way cable storage	Upper side windows (above LH door & RH slider)
Fuel/water separator	Battery disconnect switch	Skylight window in roof
Engine block heater	Air restriction indicator	Cab fan
Oil pan heater	Amber beacon light	AM/FM radio/CD w/ aux input, speakers & antenna
Beavertail	Spot/work/flood lights	5# ABC fire extinguisher
Rear flexible fenders		Additional instrumentation
Trailer stops/full cab guard		

Vehicle Ratings

Vehicle tare weight, front	
Vehicle tare weight, rear	
GAWF	13,200 lbs
GAWR	23,000 lbs
GCW	80,000 lbs

Performance

Basic Warranties (Industry Best)

Autocar terminal tractor	1 year or 3,000 hours whichever occurs first, parts & labor
Cummins engine	2 years parts & labor
Dana axles	3 years parts & labor
Allison transmission	4 years parts & labor
Frame	7 years or 20,000 hours whichever occurs first

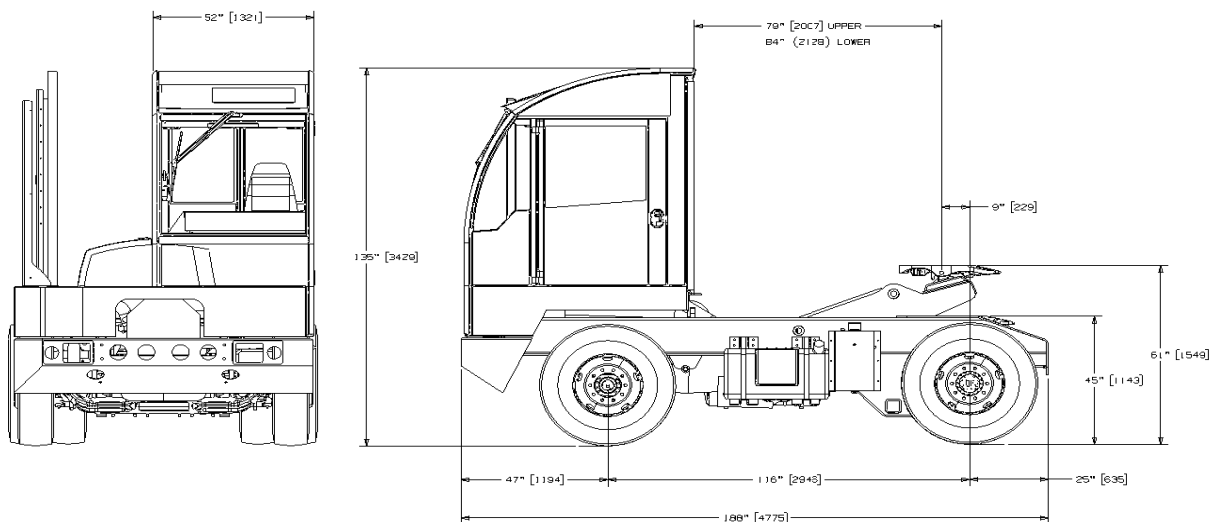

Autocar Industries, LLC • 551 South Washington Street • P.O. Box 190 • Hagerstown, IN 47346
 Toll Free: 877-973-3486 • Fax: 765-489-5230 • www.autocartruck.com